

# bosal

**Инструкция по монтажу  
тягово-цепного устройства  
шарового типа 4331 А  
для автомобилей  
Nissan Almera (4 дв.)**

	2000/4—2007
	1200
	75
	14,86



462800,

« - »  
18  
: (35363) 7-05-06  
/ : (35363) 7-13-20  
(495) 799-13-46

[www.bosal-autoflex.ru](http://www.bosal-autoflex.ru)  
[www.bosal.com](http://www.bosal.com)

« - »	(8182) 22-48-15
"	" 8(8442) 98-74-98
"	" " 8(343) 379-39-89, 373-42-73
"	" " 8(343) 26-88-308
"	" " 8(3952) 710-194
"	" " 8(495) 777-54-59
"	" " 8(495) 745-79-11
"	" " 8(495) 788-95-97
"	" " 8(495) 720-51-03
"	" " 8(3532) 57-99-85
"	" " 8-905-899-5012
"	" " 8(383) 291-59-60
"	" " 8(831) 279-53-24
"	" " 8(3422) 98-27-20
"	" " 8(342) 220-87-87
"	" " 8-927-002-90-06
"	" " 8(3462) 24-00-44
"	" " 8(3842) 21-14-76
"	" " 8-902-940-4151
"	" " 8(3452) 32-22-12, 41-52-62
"	" " 8-961-213-0278
"	" " 8-917-347-1700
"	" " 8(351) 269-44-75, 900-72-73
"	" " 8(3512) 773-76-91

41.55-2005.

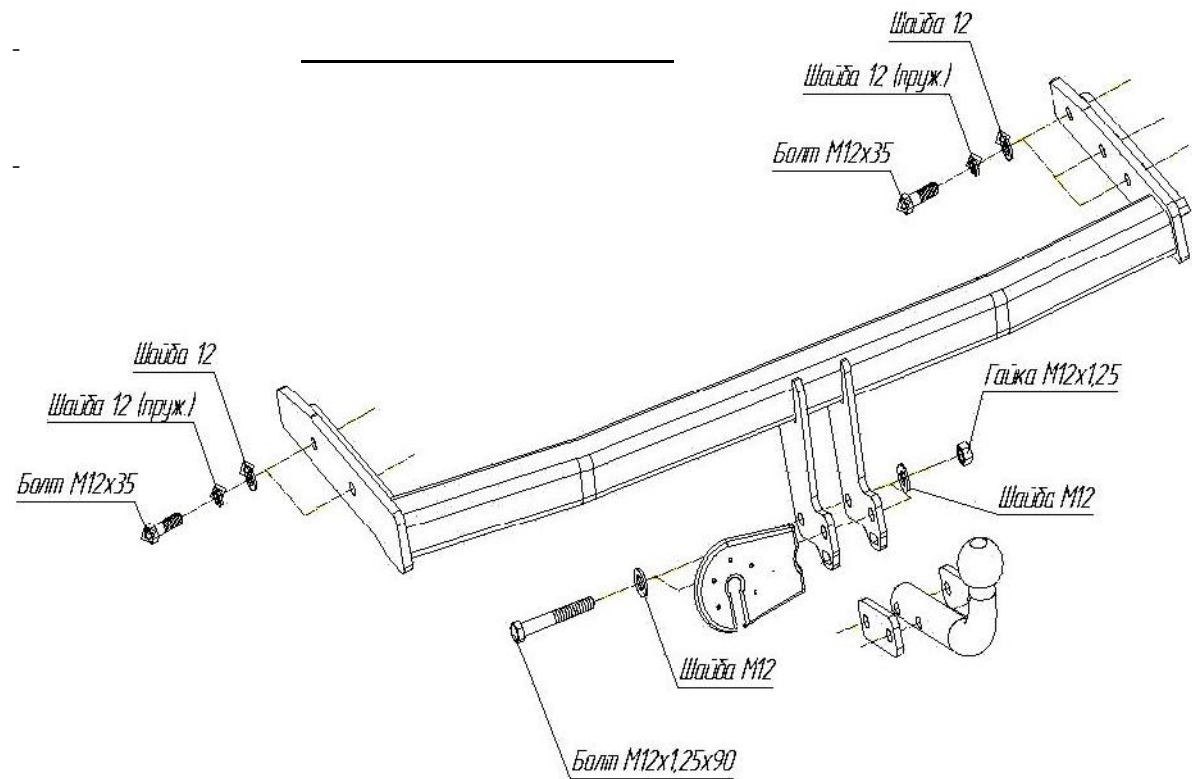

	1 .
	1 .
	1 .

	3 .
12 35	5 .
12 1,25 90	2 .
12 1,25	2 .
12 ( . )	5 .
12	9 .
	2 .
VH 0216	1 .
	1 .
	1 .
190	1 .
	1 .
	1 .

